

CVD

Equipment Corporation

enabling tomorrow's technologies™

COMPANY PRESENTATION

January 2024

CVD
Equipment
Corporation

n
firstnano

SDC

Safe Harbor Statement

This presentation contains “forward-looking statements”, within the meaning of the safe harbor provisions of the U.S. Private Securities Litigation Reform Act of 1995, as amended, that are based on management’s expectations, estimates, projections, and assumptions. Words such as “believes,” “anticipates,” “expects,” “estimates,” “plans,” “intends,” “will,” and variations of these words and similar expressions are intended to identify forward-looking statements. Forward-looking statements include, but are not limited to, those regarding anticipated growth and trends in our businesses and markets, industry outlooks and demand drivers, our investment and growth strategies, our development of new products and technologies, our business outlook for current and future periods, and other statements that are not historical facts. These statements and their underlying assumptions are subject to risks and uncertainties and are not guarantees of future performance.

Factors that could cause actual results to differ materially from those expressed or implied by such statements include, without limitation: competition in our existing and potential future product lines of business, including our PVT150 and PVT200 systems; our ability to attract and retain key personnel and employees; our ability to obtain financing on acceptable terms if and when needed; uncertainty as to our ability to develop new products for the high power electronics market including our plan to develop a PVT200 to grow silicon carbide crystals for 200mm wafers and epitaxy equipment for silicon carbide wafers; uncertainty as to our future profitability; uncertainty as to our ability to adequately obtain raw materials and components from foreign markets in light of geopolitical developments; and the continued effect of the COVID-19 pandemic on our business and operations (including with respect to supply chain disruptions), and those of our customers, suppliers and other third parties and other risks and uncertainties described in our SEC filings on Forms 10-K, 10-Q and 8-K, and from time-to-time in our other SEC reports. All forward-looking statements speak only to management’s expectations, estimates, projections and assumptions as of the date of this presentation. The Company does not undertake any obligation to update or publicly revise any forward-looking statements to reflect events, circumstances, or changes in expectations after the date of this presentation.

Key Markets



High Power Electronics

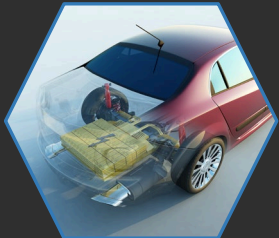

EV Battery Materials/Energy Storage



Aerospace & Defense

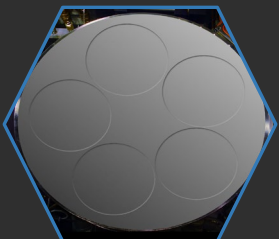

Industrial SiC Coating Equipment

CVD Equipment Corporation

CVDE designs and manufactures turnkey materials deposition and thermal process equipment to the Power Electronics, Energy Storage, Aerospace & Defense, and Industrial SiC Coating Equipment Market

About CVDE:

- Manufacture Complete Turn-Key Systems
- Service customers with demanding material performance requirements
- Provide relentless commitment to customer satisfaction
- Deliver competitive advantage to our customers through innovation, market focus and operational excellence

Market Drivers:

- *“Electrification of Everything”*
Electric vehicles (EVs) driving demand for **Silicon Carbide Wafers** for High Power Electronics Applications; Charging & Power Distribution and High-Performance **Battery Materials**
- Green, Efficient Aerospace & Defense
Fuel-efficient aircraft driving demand for **Ceramic Matrix Composite (CMC) materials** in gas turbine engines

CVDE’s Value Proposition:

- 40+ Years Providing Equipment & Process Solutions
- High Quality Components & Systems Built in the USA
- In-House Process Development Laboratory
- Proprietary Software & Control System Platform
- Vertically-Integrated Manufacturing
- Global Account Management and Customer Engagement
- High Touch Customer Service

40+ YEARS IN PROCESS
EQUIPMENT

NASDAQ: CVV

~120 Employees
Worldwide

CVD Equipment Corporation At a Glance

✓ Uniquely positioned to address high-growth Silicon Carbide (SiC) market driven by global EV adoption

✓ Provides reliable and precise equipment and solution systems to our customers in our key growth markets

✓ Proven track record of customer engagement and satisfaction through on-time delivery and customer support

✓ Operating in key markets that have significant growth opportunities

✓ Seasoned Management Team with deep global manufacturing expertise



Key Markets

High-Growth



SiC High Power Electronics

Emerging



EV Battery Materials/ Energy Storage

Legacy



Aerospace & Defense

Emerging



Industrial SiC Coating Equipment

Key Products Overview



PVT-200™
SiC Crystal Growth System



PowderCoat-1100™
Grows Silicon Nanowires on Carbon Nanoparticles



CVD/CVI Systems for Aerospace, Industrial CMC Material Deposition

CVD Equipment's Transformation

1.0 Creation and Validation

Founded to Focus on Designing and Manufacturing Key Process Equipment Solutions

- 40+ years of developing deep relationships with blue-chip industry leaders, innovative start-ups and leading research institutes
- Demonstrated wealth of IP and know-how in semiconductor market
- Decades of experience in compound semiconductor applications including developing SiC Physical Vapor Transport (PVT) systems



1982

2020

2.0 Transformation

Strategically Repositioning to Serve High-Growth Markets

- Reoriented strategy for growth and return to profitability with change in management CEO Manny Lakios and CFO Richard Catalano
- Transitioned focus from Design Make-to-Order, to Make-to-Order, with objectives of increased revenue, improved gross margin and ROI
- Increased R&D investment on high-quality, reliable tools that serve rapidly growing markets
- Renewed emphasis on customer engagement with expansion of Sales & Marketing initiatives

2021

2023

3.0 Industry Leader

Established Leader with Growing Market Share

- Robust customer engagement to deliver best-in-class tools to dominant industry players
- Continue to expand foothold with several industry leaders by replacing existing incumbents and adding to capacity
- Continued investment in R&D growing the portfolio offered within the markets



2024

2030+

Corporate & Equipment Product Lines



Corporate Headquarters and Parent Company Equipment Operations
Two Primary Operating Facilities

128,000 ft² Facility
Central Islip, New York 11722



Production CVD
and Thermal
Process Equipment
Central Islip, New York



R&D and Pilot
CVD Process
Equipment
Central Islip, New York



Ultra High Purity (UHP)
Gas & Chemical
Delivery Systems
SDC[®] Facility, Saugerties, NY



40 Years of State-of-the-Art Equipment

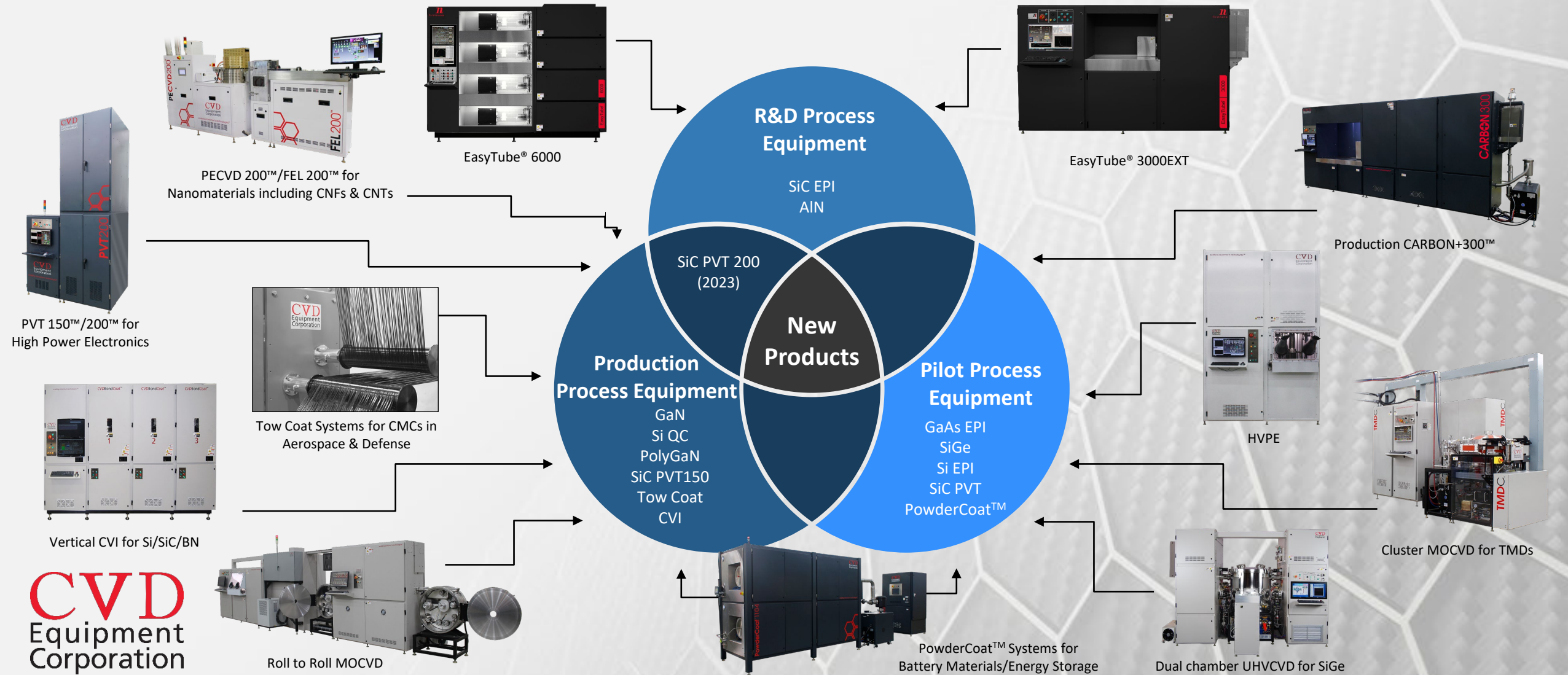

Over 40 Years of Enabling Technology in Semiconductor Equipment

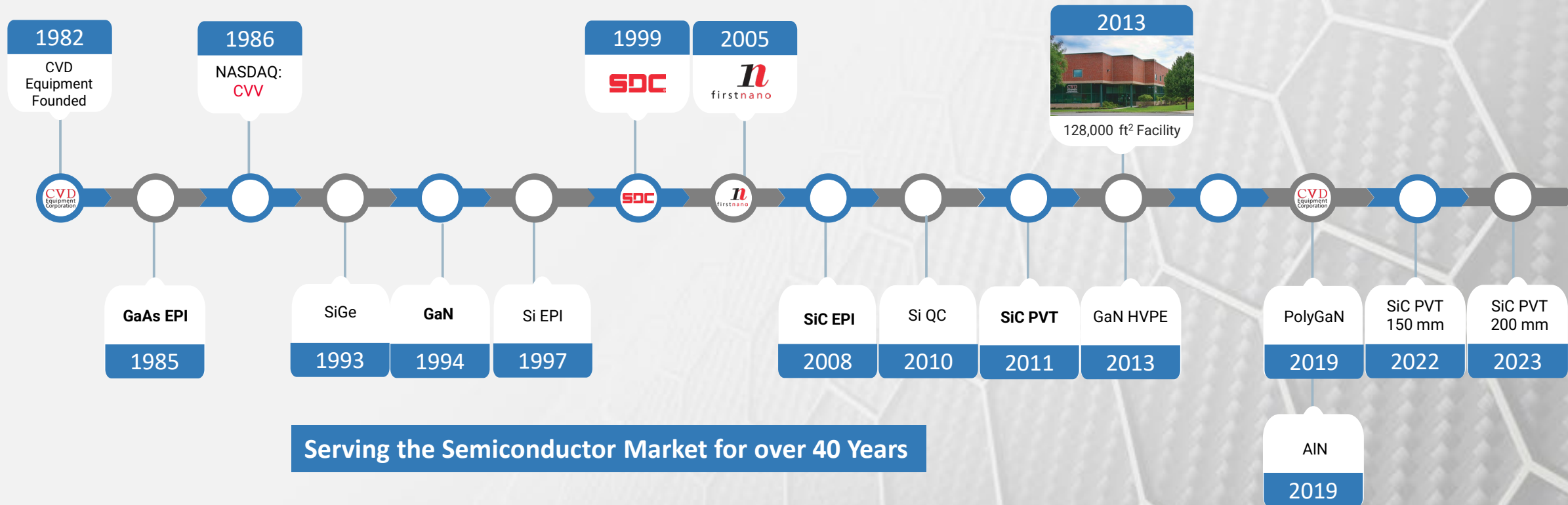

Serving the Semiconductor Market for over 40 Years



Advanced Modeling and Design Capabilities

Computational thermal and gas modeling enables simulation, aiding system development and optimization of complex materials processing equipment

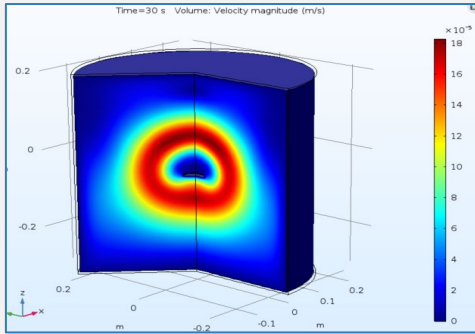

Temperature Modeling

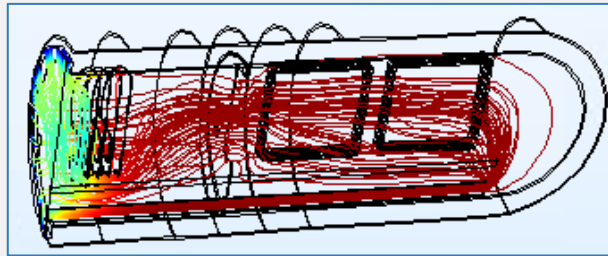
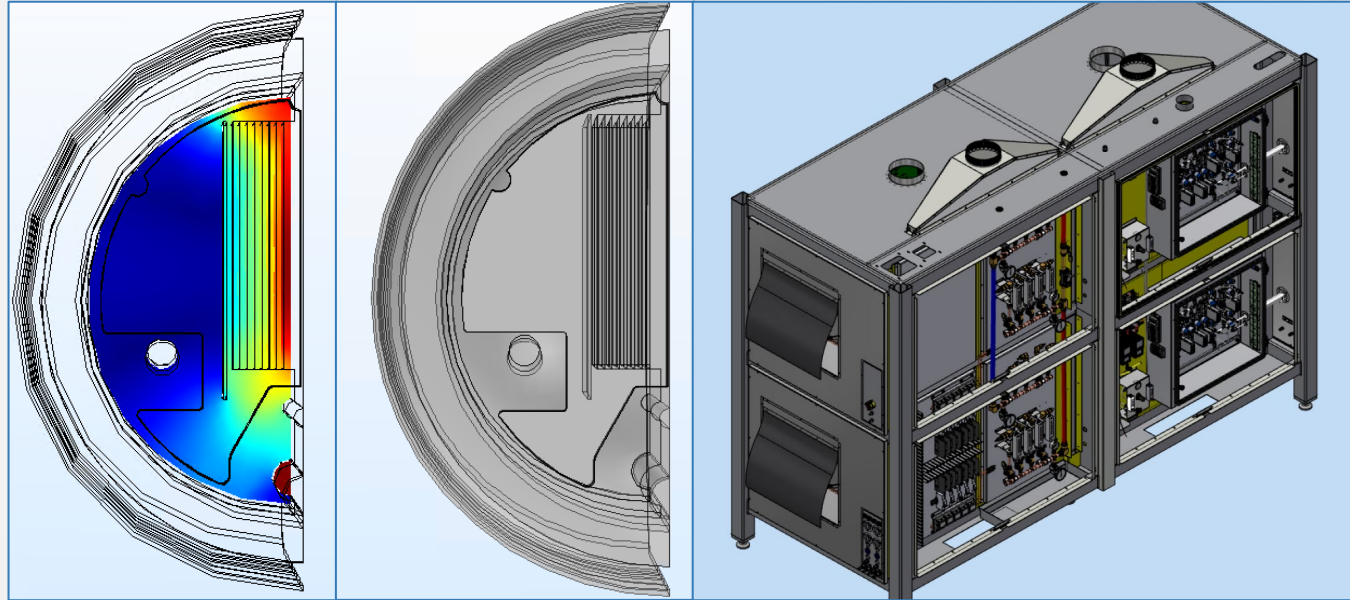

Gas Velocity Optimization

Computational Modeling

Comprehensive Component and System Design

Vertically-Integrated Manufacturing

- Leveraging over 40 years of CVD tool design knowhow
- Reducing time-to-market



CVD
Equipment
Corporation

Vertically Integrated Manufacturing - Built in the USA



Applications Lab

New materials, coatings and processing techniques through CVD's Application Laboratory

Innovative carbon (CNT, graphene) products for energy storage, sensing and biomedical devices

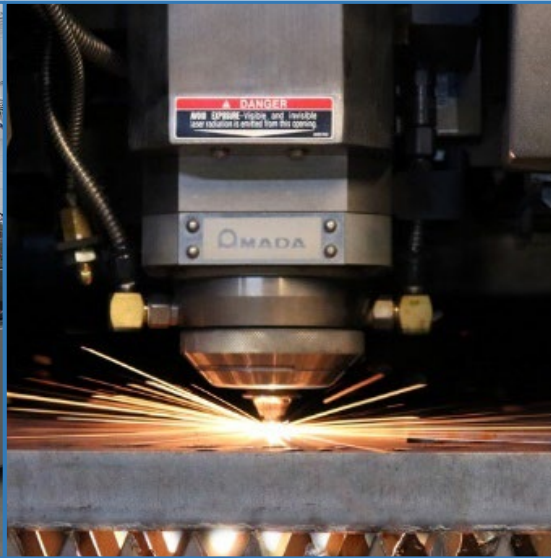

Manufacturing

CVD has expanded its internal manufacturing capabilities in 2022 with new machining centers

Vertically-integrated, >95,000 ft² of total manufacturing space

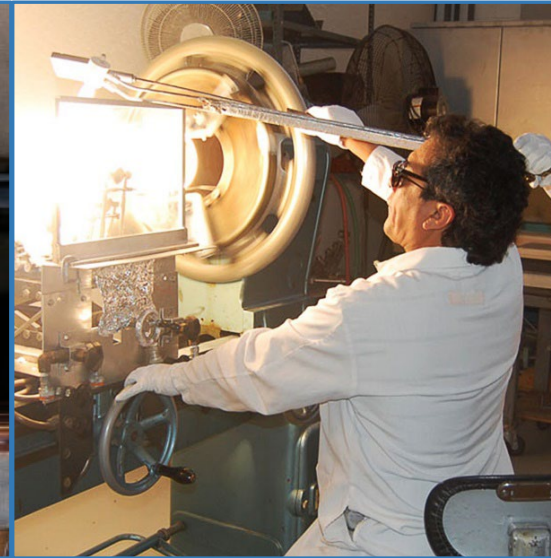

Quartzware

Our quartzware manufacturing facility can produce prototype designs with rapid turnaround

Substrate paddles, wafer boats, process gas injectors, process tubes, quartz bubblers, bell jars, etc.

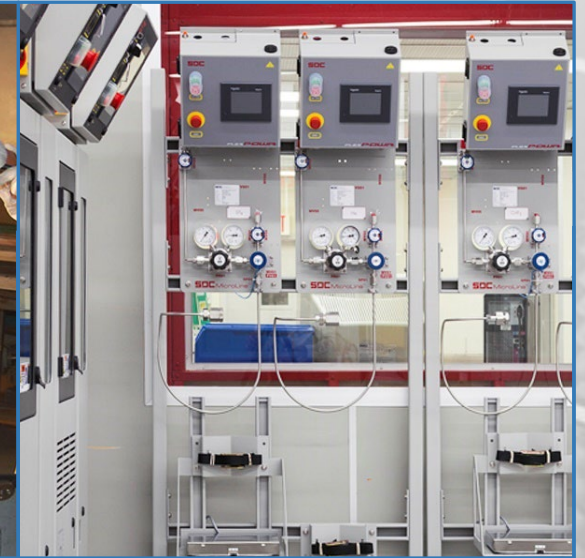

SDC[®] Gas Storage & Chemical Delivery Systems

Manufacturer of ultra-high purity gas and chemical delivery systems for the semiconductor industry as well as in microelectronics, nanomaterial production and aerospace markets

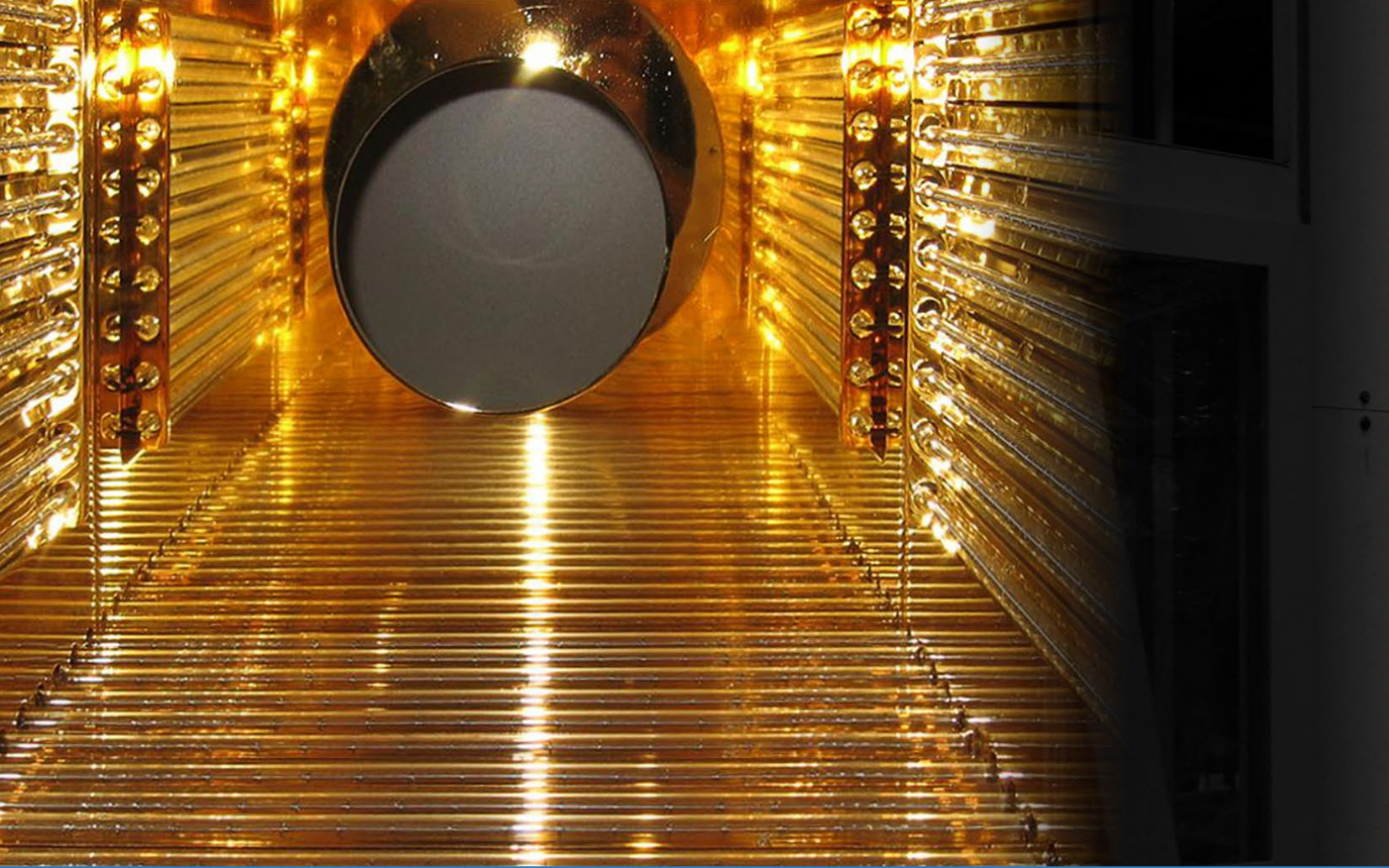

Market Overview

Growth, Strategic & Emerging Markets



The need to deploy greener and more environmentally sustainable solutions continues to expand

- Replacing fossil fuels with Renewables (wind, power, solar), Electric Vehicles (EVs)
- Reducing Emissions, CO₂ and other Green House Gases

“Electrification of Everything” and Energy Efficient, Next Generation Materials



High Power Electronics

EVs driving the demand for **silicon carbide wafers** required for devices used for power distribution and charging. Higher power density and efficiency than silicon-based devices increases EV range and enables faster charging times.

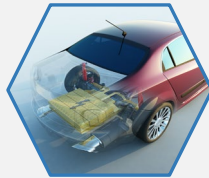

EV Battery Materials

EVs driving the demand for **advanced battery materials**. Coating graphite anode powder with silicon increases energy density, enabling expanded driving range and faster charging times.



Aerospace & Defense

Demand for **Ceramic Matrix Composite materials (CMCs)** for applications requiring high temperature and enable greater fuel efficiency in aviation propulsion

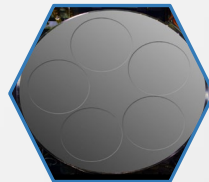

NEW Emerging Market: Demand for production **CVD systems to coat graphite components with SiC** to support semiconductor market

Key Markets



High Power Electronics

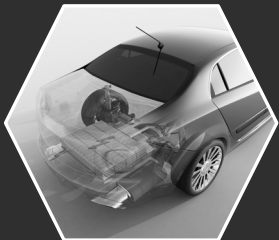

EV Battery Materials/Energy Storage

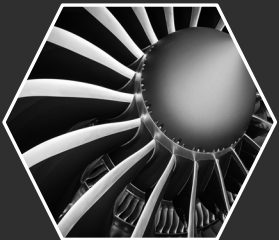

Aerospace & Defense

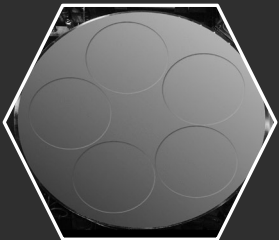

Industrial SiC Coating Equipment

High Power Electronics Market Drivers

Electric vehicles (EVs) driving the demand for **Silicon Carbide Wafers** for High Power Electronics Applications

- SiC has a bandgap that is 3X that of silicon, a thermal conductivity that is also 3X higher and a breakdown field that is 10X greater^[1]
- Device manufacturers are now pursuing a 200 mm path to SiC wafer manufacturing in addition to 150 mm
- Demand for Silicon Carbide Wafers to reach 8 million units annually by 2030^[2]

CVDE's Equipment Solutions

Physical Vapor Transport for SiC 150 mm & 200 mm Crystal Boule Growth

^[1] Status of silicon carbide (SiC) as a wide-bandgap semiconductor for high-temperature applications: A review - ScienceDirect

^[2] SiC and Shovel Approach Silicon Carbide Supply/Demand Update William Blair Equity Research 2023



- Silicon Carbide (SiC) power electronics provides higher power density and higher efficiency than silicon-based technologies, enabling faster charging times and expanded EV range
- Global SiC device market growing at 27% CAGR from \$4.2B in 2023 and projected to be \$22B in 2030^[2]

Established Players in the High Power Electronics and SiC Wafer Market



enabling tomorrow's technologies™

Adoption of SiC Devices in EVs

Market Driver:

EVs play a key role, they are the first mass-volume application to adopt SiC Traction Inverters

- Silicon MOSFETS and IGBTs are being replaced with smaller SiC devices that allow faster switching and can operate at higher temperatures and operating voltages^[1]
- Inverters play a critical role in EV performance and driving range with power-efficient components that can extract more energy from the battery at a higher efficiency^[1]

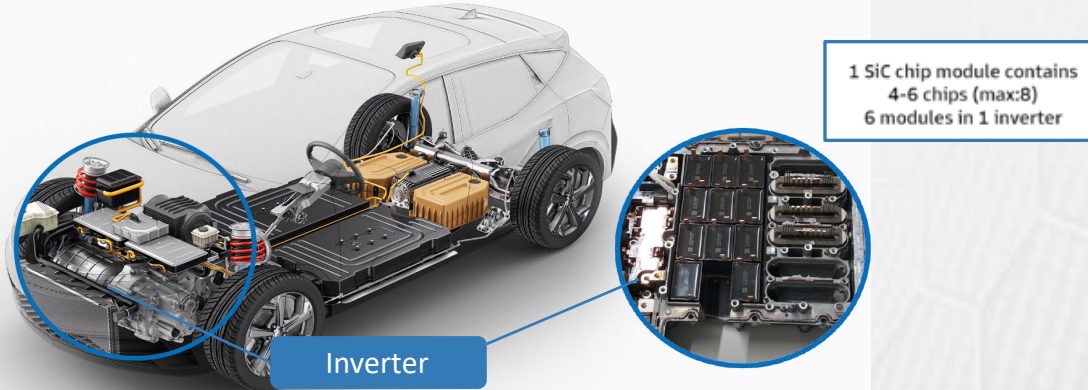

Power SiC device market Forecast by segment

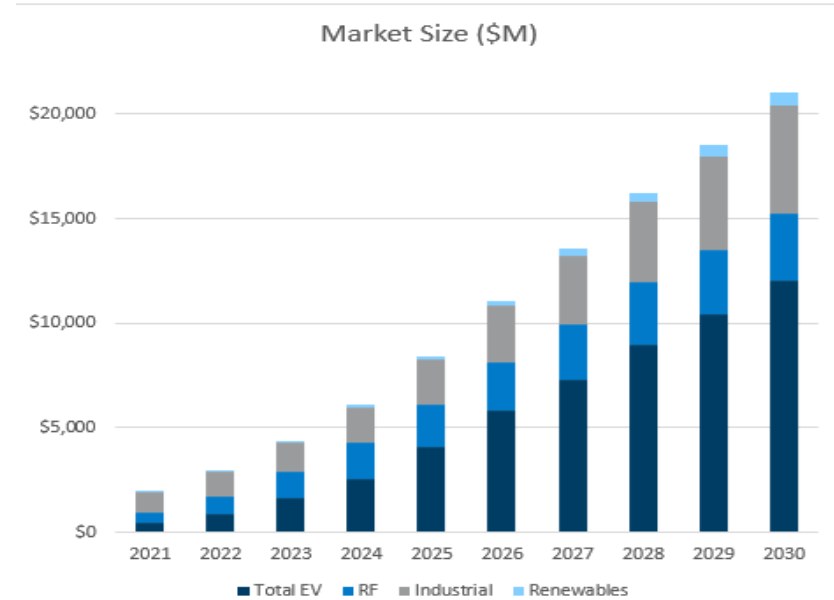

William Blair Equity Research 2023^[4]

- By 2028, EV inverter applications are expected to represent >75% of SiC device market^[2]
- Annual global sales of EVs could reach approximately 45 million by 2030^[3]
- SiC Power Electronics in EVs accelerating the demand for SiC material

Global SiC device market for 2023 at \$4.2 billion, reaching \$22 billion by 2030 w/ CAGR of 27%^[4]

Electric Vehicles (EVs) are the largest market segment

Increased device demand requires increased SiC wafer production capacity, driving demand for Physical Vapor Transport (PVT) and EPI Systems

[1] <https://www.eetimes.com/why-sic-mosfets-are-replacing-si-igbt-in-ev-inverters/>

[2] SiC & GaN Update The Beat Goes On, Jeff Perkins, Yole Intelligence - PowerAmerica August, 2023

[3] Global EV Outlook 2023 – Analysis – IEA ; Global EV Outlook 2023: Catching up with climate ambitions (windows.net)

[4] SiC and Shovel Approach Silicon Carbide Supply/Demand Update William Blair Equity Research 2023

Key Markets



High Power Electronics

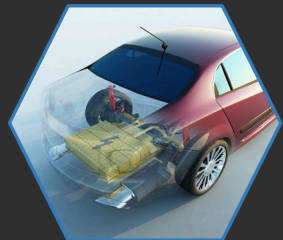

EV Battery Materials/Energy Storage

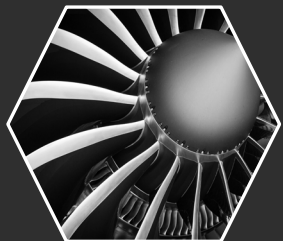

Aerospace & Defense

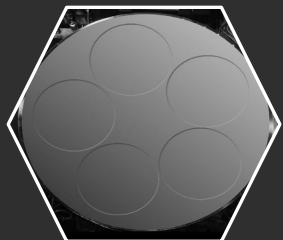

Industrial SiC Coating Equipment

EV Battery Materials, Energy Storage Market Drivers

Demand for improved Charging and Power Distribution and Higher Performance Battery Materials for longer driving range at reduced cost

- Next-generation battery technologies are being developed and evaluated
- Battery material manufacturers are developing carbon/silicon anodes either by mixing silicon, depositing silicon or growing silicon nanowires onto graphite powders to enhance the electrical performance of battery anodes^[1]
- Silicon has the capacity to store up to 10X more energy than conventional graphite alone^[1]



- Global EV battery projected market in 2023: \$64B ^[2]
- Battery market projected to be \$276B in 2030 with a CAGR of 23% ^[2]

CVDE's Equipment Solutions

1. Deposition/Infiltration of coatings and nanowires onto powders (silicon, carbon, metals, oxides, etc.)
2. Equipment Solutions for R&D and High-Volume Manufacturing
3. Equipment for R&D and Production for growing CNTs onto substrates (foils, wafers etc.)

[1] <https://www.powerelectronicsnews.com/nanosilicon-graphite-anodes-increase-efficiency-of-next-gen-ev-batteries>

[2] <https://www.precedenceresearch.com/electric-vehicle-battery-market>

Key Markets



High Power Electronics

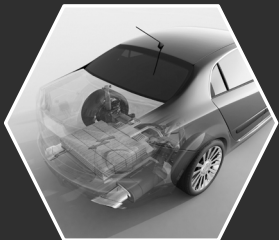

EV Battery Materials/Energy Storage



Aerospace & Defense

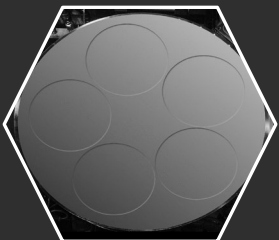

Industrial SiC Coating Equipment

Aerospace & Defense Market Drivers

Demand for **Ceramic Matrix Composite Materials (CMCs)** in gas turbine engines to reduce weight and enable greater fuel efficiency

- Gas turbine engine OEMs are adopting CMC components within new engine platforms
- Published reports from established engine manufactures including CFM International (LEAP engine), GE Aerospace (GE9X), Rolls Royce (UltraFan), P&W, Safran, etc. [1-5]
- CMC components reduce fuel consumption up to 2% as they are lighter weight and require less cooling compared to conventional nickel-based components [1]
- CVDE has shipped ~\$70M in process equipment into the CMC market to date

CVDE's Equipment Solutions

1. Deposition/Infiltration of coatings onto CMC components
2. Deposition of Coatings onto SiC fibers to control fiber-matrix bonding and load transfer

[1] https://ceramics.org/wp-content/uploads/2019/03/April-2019_Feature.pdf

[2] <https://www.rolls-royce.com/media/our-stories/discover/2019/pioneering-cmcs.aspx>

[3] <https://newsroom.prattwhitney.com/2021-07-13-Pratt-Whitney-Opens-New-Facility-Dedicated-to-Ceramic-Matrix-Composites>

[4] [Ceramic matrix composites take flight in LEAP jet engine | ORNL](https://www.ornl.gov/newsroom/ceramic-matrix-composites-take-flight-in-leap-jet-engine)

[5] https://www.dlr.de/wf/en/PortalData/23/Resources/dokumente/wf-kolloquium/Ceramic_Matrix_Composite_behavior_enhancement_urbines_Hot_Sections.pdf

[6] <https://www.marketsandmarkets.com/Market-Reports/ceramic-matrix-composites-market-60146548.html>



- Global CMC market was valued at \$11.9B in 2022 and estimated to grow to \$21.6B by 2028 at a CAGR of 10.5%^[6]

Established Players in the CMC Market



Key Markets



High Power Electronics

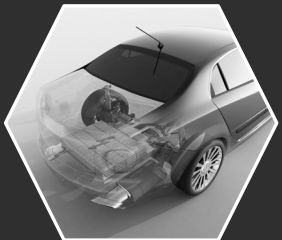

EV Battery Materials/Energy Storage

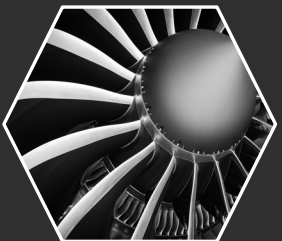

Aerospace & Defense

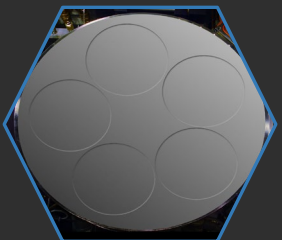

Industrial SiC Coating Equipment

Industrial SiC Coating Equipment Market Drivers

The semiconductor industry is driving the demand for Silicon Carbide (SiC) Coatings onto graphite and carbon reinforced carbon components (e.g. wafer carriers and susceptors for PECVD, Si epitaxy and MOCVD units)

- SiC Coatings provide oxidation protection, high abrasion resistance, corrosion resistance, erosion resistance and wear resistance^[1]
- Applications where high mechanical, chemical, and thermal properties are needed
- Coating extends the service life of graphite components and achieves the high-purity surface structures required in processing semiconductor materials^[1,2]

CVDE's Equipment Solutions

Chemical Vapor Deposition Furnace System for Silicon Carbide coatings

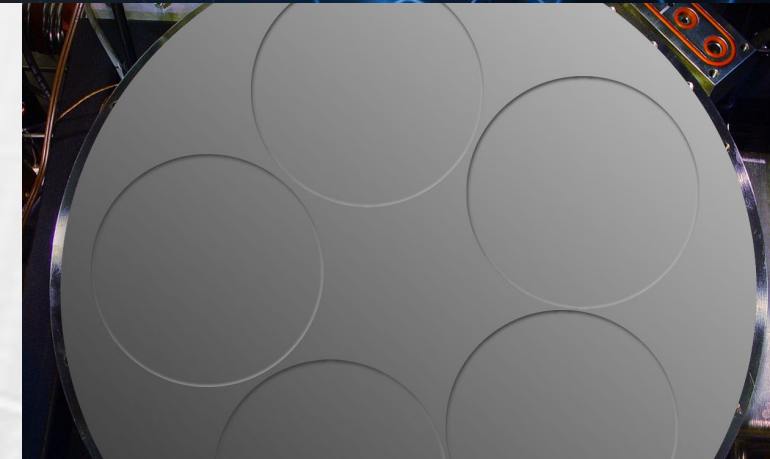

- Silicon Carbide coatings protect graphite products from oxidation & degradation under aggressive processing conditions^[3]
- Global SiC Coating Market is growing at 21.5% CAGR from \$343.1M in 2022 and projected to reach \$1.1B in 2028^[1]

Established Players in the Carbon/SiC Coating Market



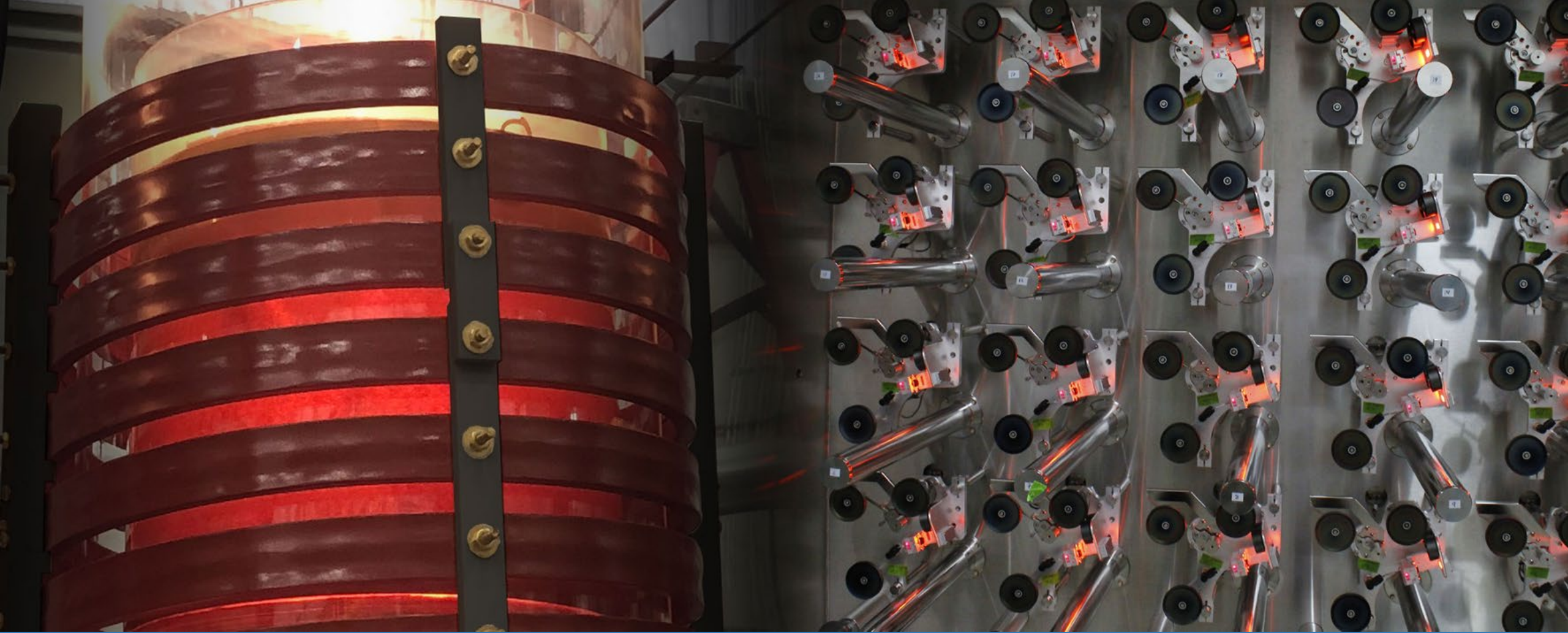

Product and Technology

High Growth CVD SiC Wafer Production for High Power Electronics

End-User Applications



EV Charging

EV Motor Power Conversion

Power Grid Transmission

Process Solutions



PVT 150 mm SiC Crystal Growth System (2022)

PVT 200 mm SiC Crystal Growth System (2023/2024)

Key CVD Strengths



Temperature, Pressure and Overall Process Control

Process Uniformity and Repeatability

Safety and Control System

Focus on Customer Cost of Ownership

State-of-the-Art Equipment Addressing SiC Wafer High-Growth Market



2022: Launched PVT150™ Crystal Growth System
2023/2024: Launch of PVT200™ Crystal Growth System

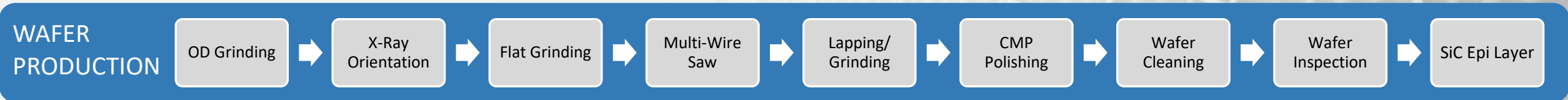

CVD Positioned To Take Advantage of Key Industry Trends over next 1-2 years^[1] with expanding internal capacity

- Shift from 150 mm to 200 mm SiC manufacturing to reduce device costs
- Improve SiC quality and uniformity to increase yield and reduce costs

Present Capacity: 12 Systems/Month, Potential Capacity: 25 Systems/Month (potential annual capacity up to 300 systems)



^[1] Goldman Sachs, "The Green Technology Cycle SiC" Takayama et. Al., 24 JUNE 2022

PVT150™ / PVT200™ Go To Market Launch

- PVT R&D System: 2011
- PVT150™ launched & installed 30 Systems – 2022/2023
- PVT200™ launch – 2023/2024

Differentiating Features and Options

- Robust Production System with Enhanced Process Controls
 - Temperature Control +/- 0.5°C @2500°C
 - Pressure Control +/- 0.5%
 - Enhanced Process Monitoring Control System
- Time to market, internal vertical manufacturing yields 6-month lead time



PVT200™
Physical Vapor Transport System

Carbon
Nanotubes
(CNTs) on Substrates

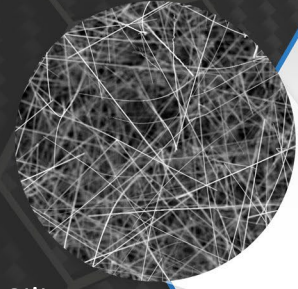

Silicon

Coating & Infiltrating
Powders with
High Performance
Nanomaterials



Increased Energy Density

- R&D and Production Systems
- Powder Tumbler Design
- High Volume CNT Processing on Substrates

CVDE is enabling innovation in EV battery technology



Complete Turn Key Systems for
Chemical Vapor Deposition & Infiltration - Gas Management - Abatement

PowderCoat 300™ - CVD R&D Systems

Features and Options

- Powder Coating - Deposition of Nanomaterials & Thin Films
- Rotating Tumbler for Uniform Mixing
 - Programmable Speed (0 - 50 RPM)
 - Volume up to 250 cc
- 3 Zone Resistance Furnace Heating Systems
- Customizable Process Chamber
 - Process Tube Inner Diameter 70 mm nominal
 - Process Tube Length 40 mm nominal
- Powder Load up to 100 cc
- Powder Particle Size Distribution Range: Sub-microns to Hundreds of Microns
- Coating Thickness Range: A few Nanometers to Tens of Microns
- Robust R&D System with Enhanced Process Controls
 - Temperature Control +/- 0.5°C
 - Pressure Control +/- 1%
- Working Pressure 0.2 – 500 Torr
- Working Temperature Max 1100°C nominal
- Rapid Cool-Down
- Glove Box for Unloading Sample Under Inert Conditions



PowderCoat 1104™ - CVD Production Systems

Features and Options

- High Volume Powder Infiltration & Coating
- Uniform Coating and Deposition of Nanomaterials & Thin Films
- Multi-Reactor Chambers for Parallel or Sequential Processing
- Low Pressure CVD
- 5 Zone Resistance Furnace Heating Systems
- Customizable Inconel Chamber
 - Process Chamber Inner Diameter 340 mm nominal
 - Process Chamber Length 3350 mm nominal
- Rotating Tumbler for Uniform Mixing
 - Powder Load up to 20 L per
- Powder Particle Size Distribution Range: Sub-micron to Hundreds Microns
- Coating Thickness Range: A few Nanometers to Tens of Microns
- Robust Production System with Enhanced Process Controls
 - Temperature Control +/- 0.5°C
 - Pressure Control +/- 1%
- Working Pressure 0.5 – 500 Torr
- Working Temperature Max 900°C nominal
- Rapid Cool-Down
- MES Compatible
- EGC 1510 HSF Gas Abatement System



1. Systems to Coat CMC Engine Components



Production Bond Coat System

- Manufacture of Low Pressure CVD Tools to Coat CMC Engine Components with Silicon
- RF Induction and Graphite Resistive Heating Options
- Process Temperatures >1600°C (2200°C Capable)
- Multi-chamber deposition systems for increased throughput

2. Systems to Coat CMC Components

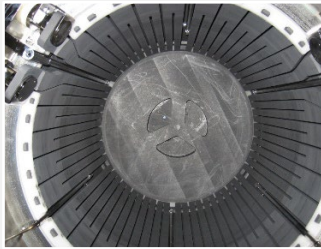

Production CVI Furnace

- Low pressure CVD tools to coat gas turbine engine components with silicon, silicon nitride, boron nitride, silicon carbide, Carbon, etc.
- RF Induction and graphite heating options
- Process temperatures up to 2200°C

3. Systems to Coat SiC Fiber used to Manufacture CMC Preforms

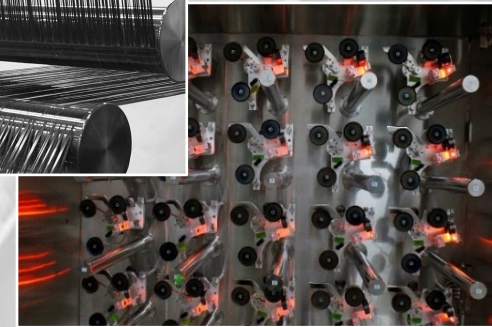

Production Fiber Tow Coating System

- Fiber Tow Coat Systems: 1-tow, 10-tow and 72 tow configurations
- In-line deposition of coatings onto Silicon Carbide fiber
- Patented fiber handling and transport systems with precise speed & tension control

Legacy CVD/CVI for Aerospace & Defense and Industrial Markets

End-User Applications



CMC Engine Components

Hypersonics

Graphite susceptors with silicon carbide coating

Process Solutions



Production Bond Coat Systems

R&D and Production CVD/CVI Furnaces

Production Fiber Tow Coating Systems

Key CVD Strengths



CVD/CVI Furnace Process Chamber: 62" ID / 77" H

Precise temperature control up to 1600°C ± 7°C

Patented fiber handling with precise speed & tension control

SDC[®] Gas and Chemical Delivery Solutions

SDC[®] Division of CVD Equipment Corporation

- Manufacturer of ultra-high purity gas and chemical delivery systems for the Semiconductor industry as well as in microelectronics, nanomaterial production, and aerospace markets
- Sustained market position, continued growth in international orders
- Provides support and critical standard products to end-user facilities as well as to CVD Equipment Corporation

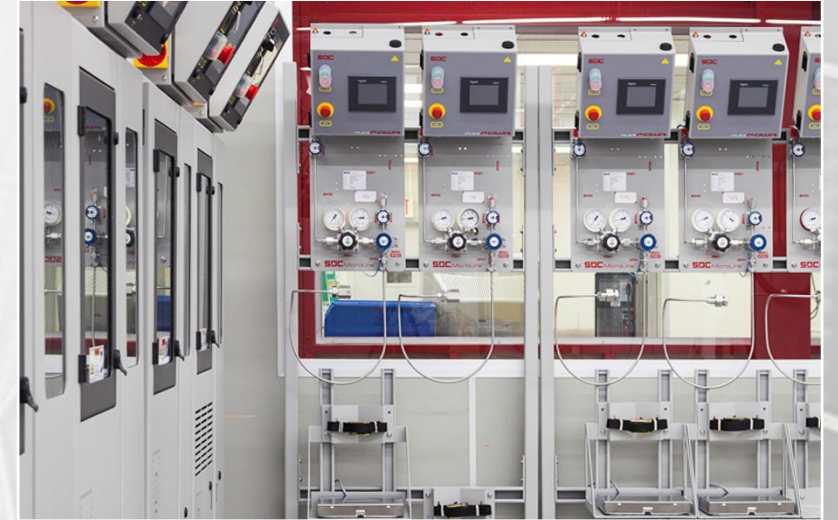

Exhaust Gas Conditioning Solutions

CVDE manufactures exhaust gas conditioning systems for safe treatment of process effluent gases

- Automated handling of flammable, hazardous, corrosive and pyrophoric gases
- CVDE's EGC™ systems removes particles from the exhaust stream and reacts exhaust biproducts with water and oxygen
- Optional pH monitoring system can neutralize the scrubbing solution



EGC610™ Pyrolyzing Wet Scrubber



EGC1510-HSF™ High Silane Flow Pyrolyzing Wet Scrubber



Liquid Scrubbing Systems

High Touch Customer Service

CVD Equipment Corporation Provides After Sales Support, Including:

- Site Survey
- Installation Coordination and Field Acceptance
 - NRTL/UL/CE Certification Available
- Initial Start-Up Support
 - On-Site Training
- Warranty Response and Remote Capability
 - Help Desk Support & Customized Service Contract Plans
- Continuous Improvement Programs and Support
- Customized Site Support Contracts
 - Spares and Consumables
 - Preventative Maintenance
 - Site Personnel Contracts



Key Markets



High Power Electronics

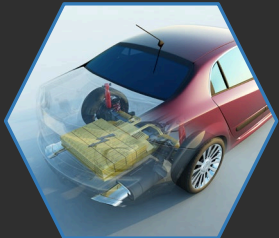

EV Battery Materials/Energy Storage



Aerospace & Defense

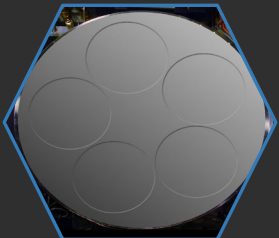

Industrial SiC Coating Equipment

Our Future is Electric, the Future is



High Quality Components & Systems Built in the USA
Manufacture Complete Turn-Key Systems



Vertically Integrated Manufacturing
CVDE's competitive advantage, enables reducing cost, reducing lead times and improving quality



Manufacturing High Volume Capital Process & Peripheral Equipment
Uniquely positioned to address massive high-growth SiC Power Electronics market driven by global EV adoption



CVD Equipment Corporation

40+ Years Providing Process Solutions
Deep global manufacturing expertise and reliable, precise leading technology process equipment to electronics, aerospace and industrial markets



Global Install Base
Over 1000 systems in the field, for the electronics, aerospace and battery materials markets



High Touch Customer Service
Proven track record of customer engagement and satisfaction through on-time delivery and high touch customer support
Service customers with demanding material performance requirements



Thank You!



PVT200™
Physical Vapor Transport System